

# How to Guide

## Retro-Fit LED Tube Conversion



FA8



G13



R17D

**PRO-WATT SUPPLY**

March 2015  
Version 1.3

## Disclaimer

As safety is our number one concern for our customers, it is the responsibility of the Installer to be familiar with the possible electrocution risks involved with connecting and working with high voltage electrical components. A professional Installer/Electrician should always be contracted whenever possible to complete the necessary LED installation modifications.

This installation Manual is proprietary to Pro-Watt Supply and no ownership rights are hereby transferred. No part of the Manual shall be used, reproduced, translated, converted, adapted, stored in a retrieval system, communicated or transmitted by any means, for any commercial purpose, including without limitation, sale, resale, license, rental or lease, without the prior express written consent of Pro-Watt Supply.

Pro-Watt Supply does not make any representations, warranties or guarantees, express or implied, as to the accuracy or completeness of the Manual. Users must be aware that updates and amendments will be made from time to time to the Manual. It is the user's responsibility to determine whether there have been any such updates or amendments. Neither Pro-Watt Supply nor any of its directors, officers, employees or agents shall be liable in contract, tort or in any other manner whatsoever to any person for any loss, damage, injury, liability, cost or expense of any nature, including without limitation incidental, special, direct or consequential damages arising out of or in connection with the use of this Guide.

## INDEX

Page 3	Important First Steps
Page 5	“Double End” LLT Style Tubes
Page 7	Recessed Contact R17D
Page 10	Double Pin G13
Page 13	“Single End” LLT Style Tubes G13
Page 14	Testing Tombstone with Ohm meter
Page 17	LED Tube Hanger Install
Page 18	Appendix

## How to Guide

### Retro-Fit LED Tube Conversion

1. Make sure breaker for the fixture is **shut off**.
2. Cover the breaker with red Electrical tape to prevent others from switching it back on.

Make Sure it's in the **OFF** position



3. Note the components of a typical Fluorescent Fixture

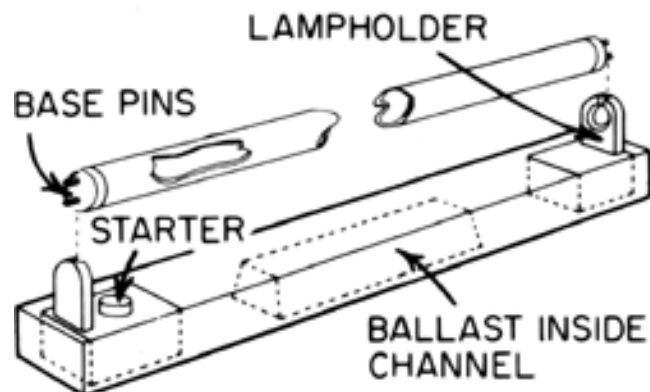

4. Remove cover on fixture, note which type of wiring configuration it has.

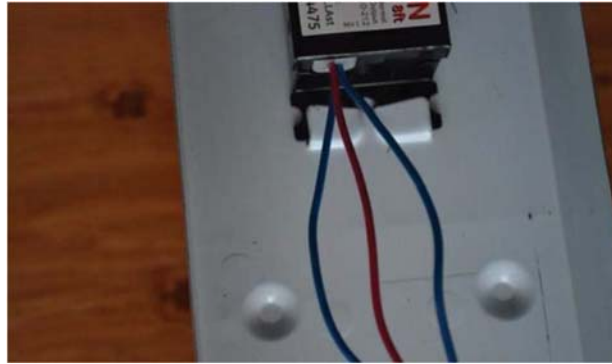

The following steps are based on the wiring style of the LED Tube. These are comprised of either the following types:

- Double-ended LED LLT, (typically the single pin design (FA8) or the Cold Start/High Output Recessed Contact (R17D) or,
- Single-ended LED LLT, dual pin (G13) 4' and smaller. For single-ended LED LLT, go to step #10

## “Double End” LLT Style Tubes

Power supplied to one end, Neutral to the other.

### FA 8 or Single Pin – 8’ LED Tubes



Please note: Either side of tube could be supplied with power or neutral unless marked on tube cap as shown below



See the following configurations below. (Please note wire color may be different)

**NOTE:** When cutting wires, you may wish to salvage the existing working ballast so keep at least 2” - 3” of wire length. Try to salvage existing wire whenever possible in the fixture to use on the retrofit

#### a. Typical Double Lamp Series Magnetic Ballast Configuration – single pin (FA8)

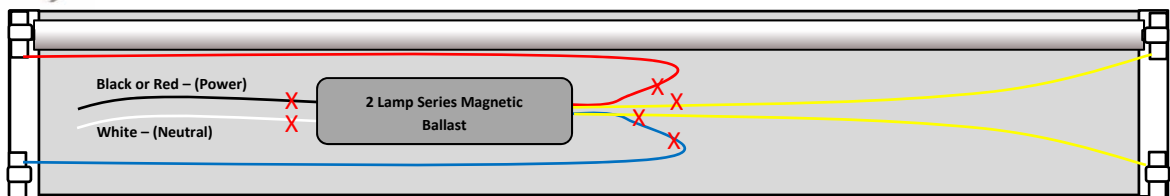

- Remove Ballast

- Connect the blue wire to the black (power) wire with a marrett. This will be the **power end**.

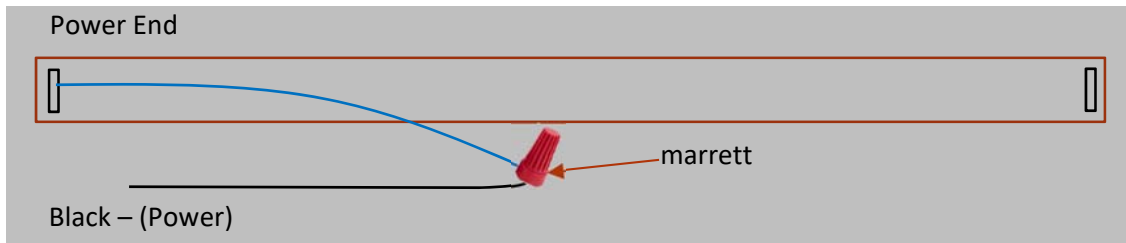

- Now connect the one (1) red wire to the white (neutral) wire with a marrett. This will be your **neutral end**.

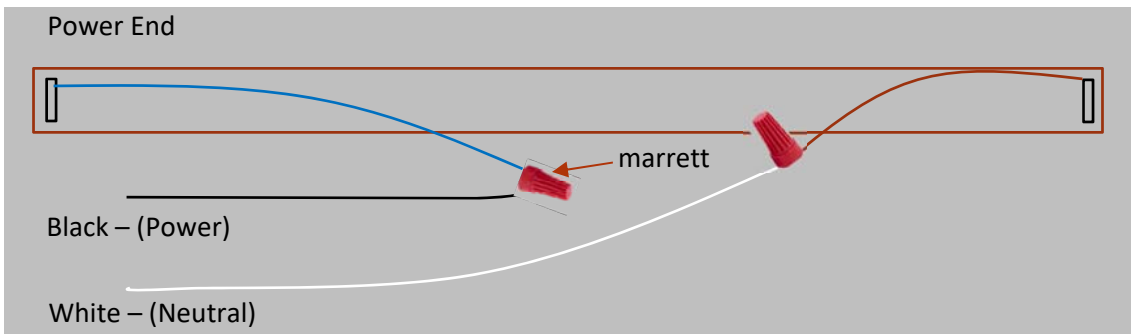

- Reinstall fixture cover
- Install LED tubes

### a. Typical Double Parallel Lamp Electronic Ballast Configuration - single pin (FA8)

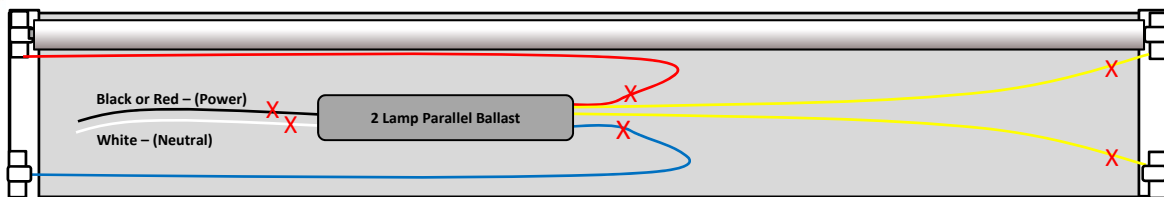

**X=**cut wires

- Remove Ballast
- Connect the two (2) blue wires to the black (power) wire with a marrett. This will be the **power end**.

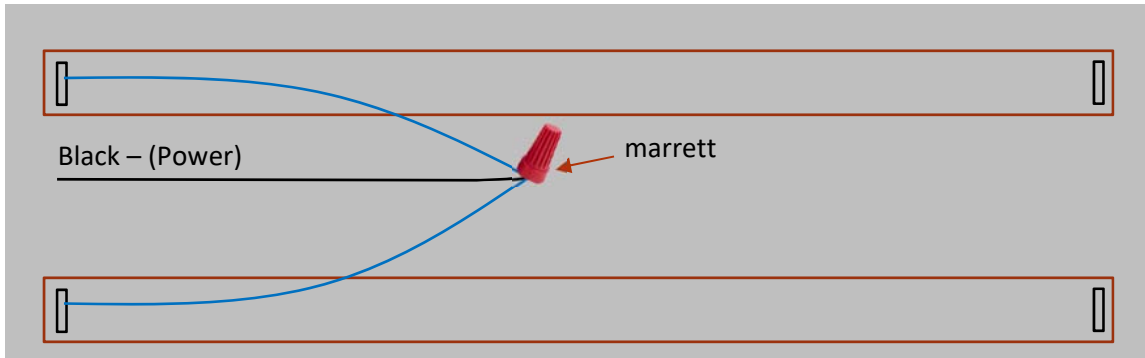

- Now connect the two (2) red wires to the white (neutral) wire with a marrett. This will be your **neutral end**.

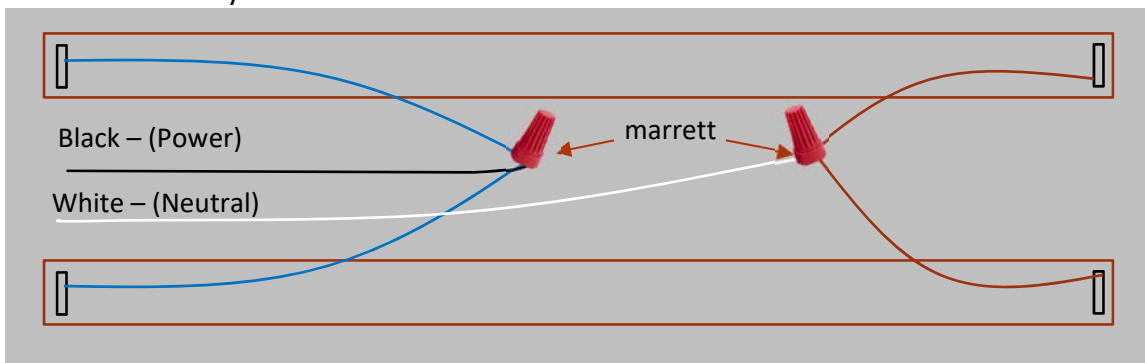

- Reinstall fixture cover
- Install LED tubes

### R17D Cold Start/High Output/Instant Start – 8' LED Tubes



**Please note: Either side of tube could be supplied with power or neutral unless marked on tube cap as shown below.**





See the following configurations below. (If the fixture you have has two wires connected to the socket on both ends of every lamp (a total of four wires per lamp), it means that you have a “Rapid-Start or Pre-Heat fixture”) These can be wired in the same way as the “Instant Start” fixture as you will use only one wire per holder. Please note wire colors may be different

**NOTE:** When cutting wires, you may wish to salvage the existing working ballast so keep at least 2” - 3” of wire length. Try to salvage existing wire whenever possible in the fixture to use on the retrofit

**a. Typical Double Lamp Series Magnetic Ballast Configuration Recessed Double Contact – (R17D)**

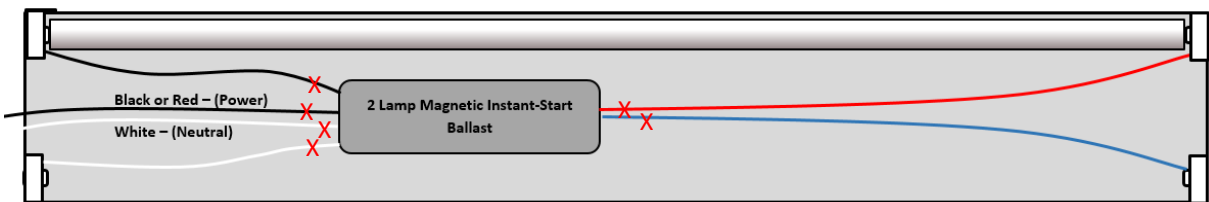

 **X=cut wires**

- Remove Ballast
  - Connect the black and white wire (add black electrical tape to indicate hot) to the black (power) wire with a marrett.
- This will be the **power end**. **Either side of the tube holder can be used as power.**

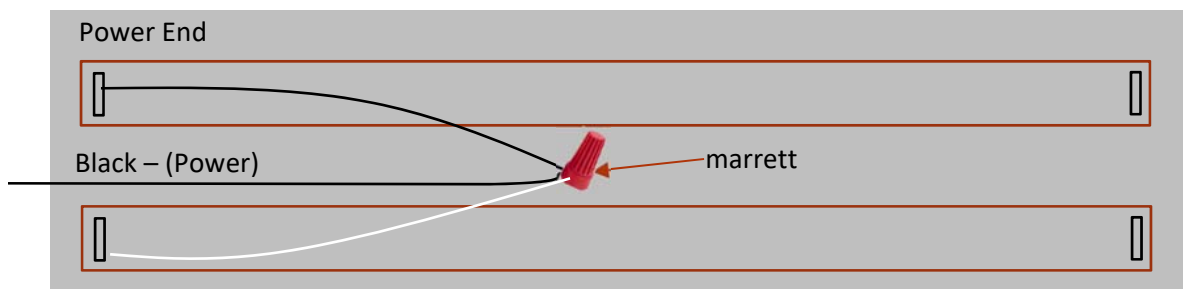

- Now connect the red and blue wire to the white (neutral) wire with a marrett.
- This will be your **neutral end**. **Either side of the tube holder can be used as neutral.**

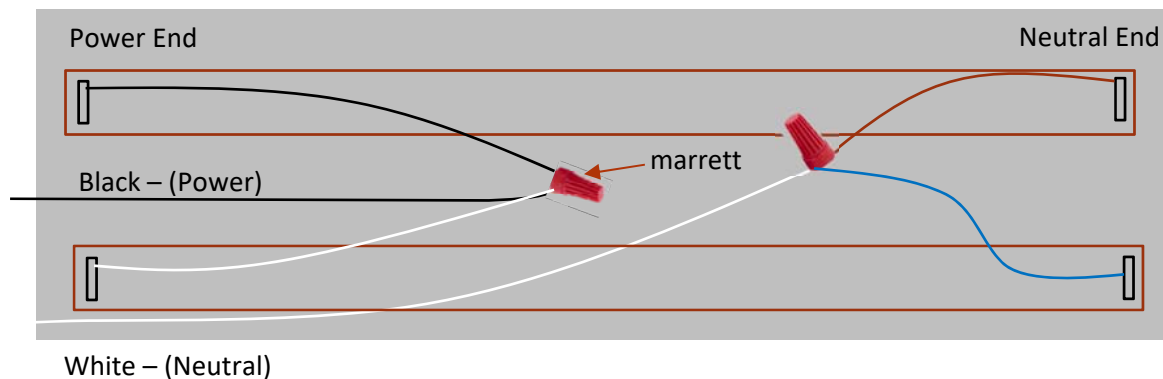

- Reinstall fixture cover
- Install LED tubes

### b. Typical Double Lamp Series Electronic Ballast Configuration Recessed Double Contact – (R17D)

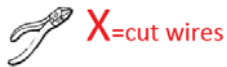
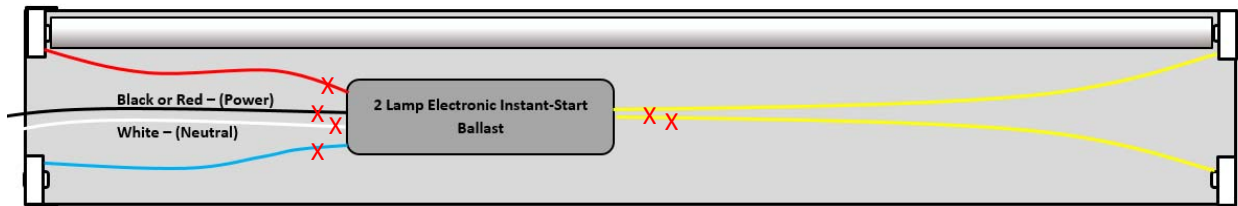

- Remove Ballast
- Connect the red and blue wire to the black (power) wire with a marrett. This will be the **power end**. **Either side of the tube holder can be used as power.**

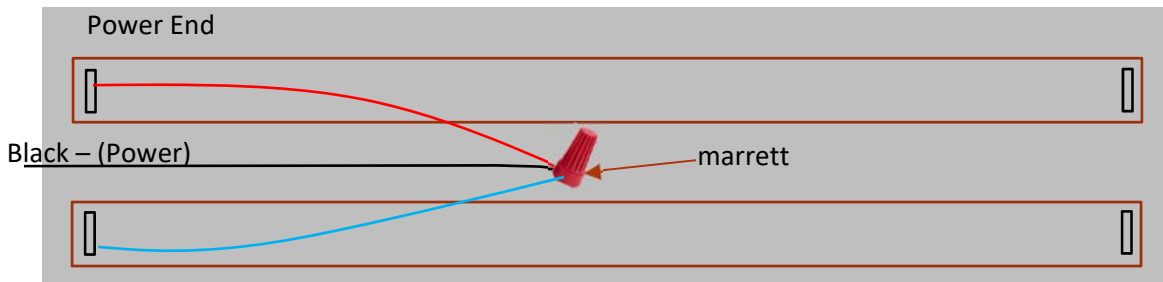

- Now connect both yellow wires to the white (neutral) wire with a marrett. This will be your **neutral end**. **Either side of the tube holder can be used as neutral.**

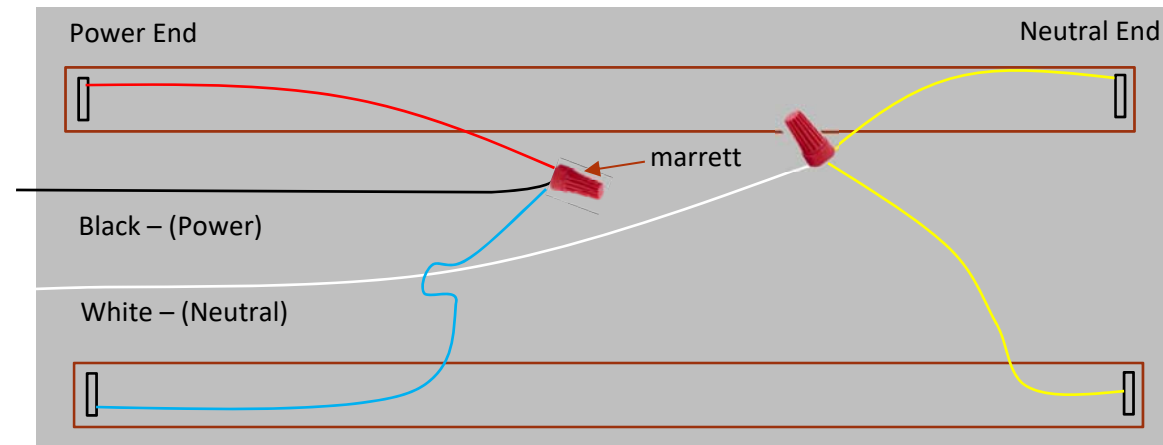

- Install LED tubes

## G13 or Double Pin – 2' & 4' Tubes

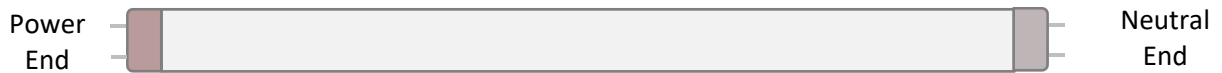

Please note: Either side of tube could be supplied with power or neutral.

### 1. Typical Double Lamp Parallel Electronic Ballast Configuration

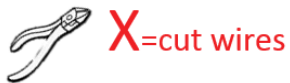
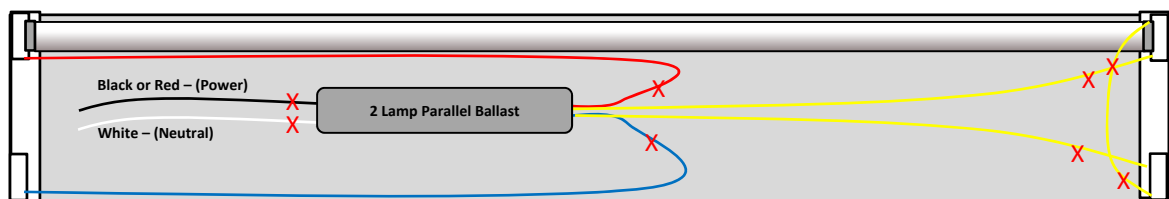

**NOTE:** When cutting wires, you may wish to salvage the existing working ballast so keep at least 2" - 3" of wire length. Try to salvage existing wire whenever possible in the fixture to use on the retrofit

- Remove Ballast
- Connect the two (2) blue wires to the black (power) wire with a marrett.

This will be the **power end**.

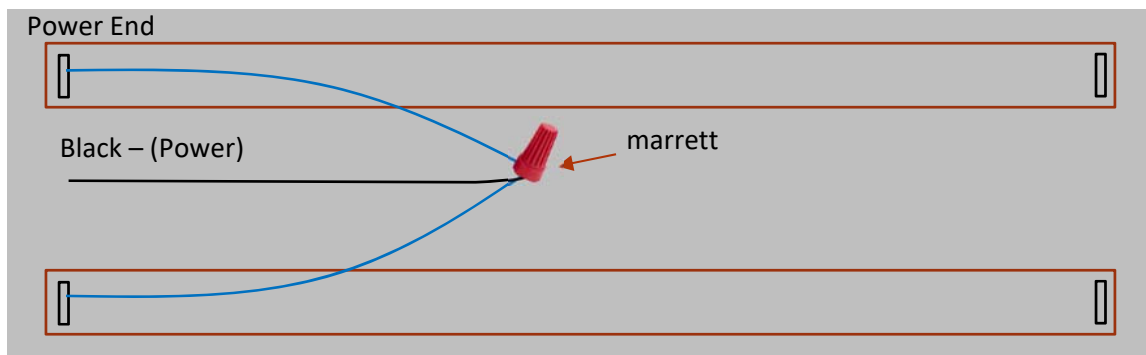

- Now connect the one (1) red wire to the white (neutral) wire with a marrett.  
This will be your **neutral end**.

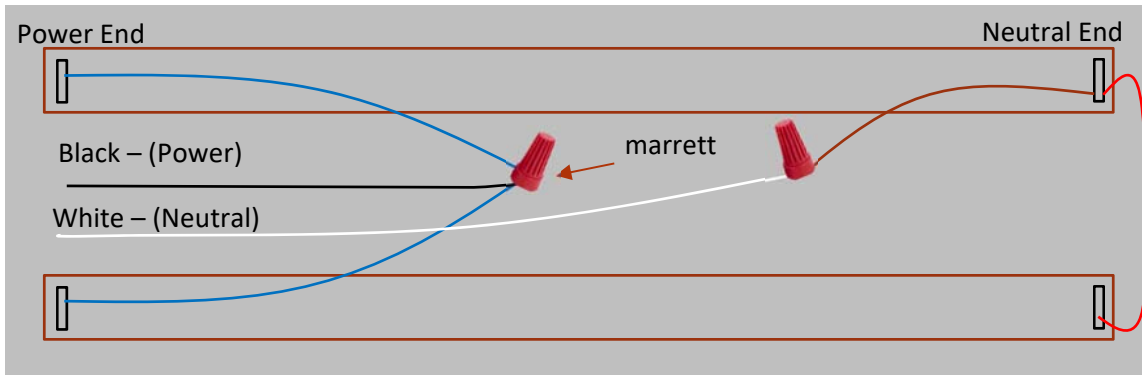

- Reinstall fixture cover
- Install LED tubes

## 2. Typical 2 Lamp Series Electronic Ballast Configuration

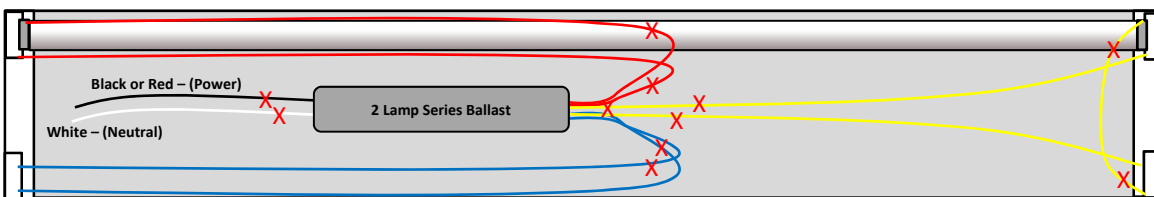

- Remove Ballast
- Cut off one red wire and one blue wire at the bulb holders on one end so that there is only one wire at each bulb holder. Connect the red and blue wires to the black (power) wire with a marrett. This will be your **Power End**.

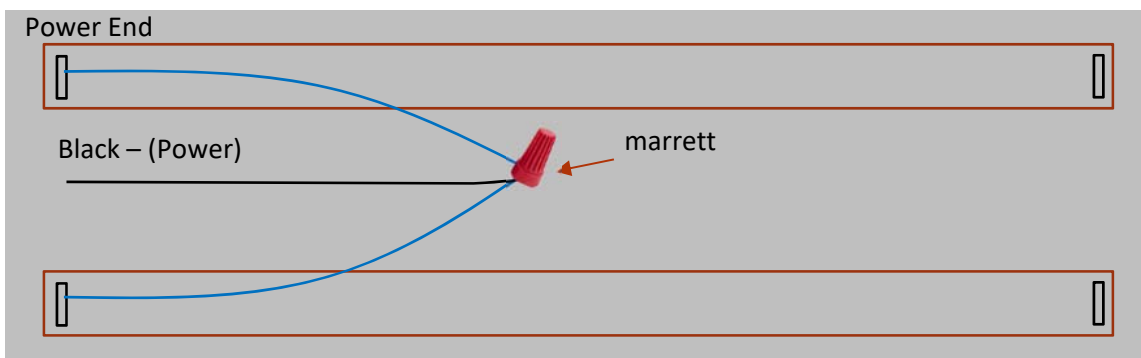

- Connect the two (2) yellow wires to the white (neutral) wire with a marrett.  
This will be your **Neutral End**.

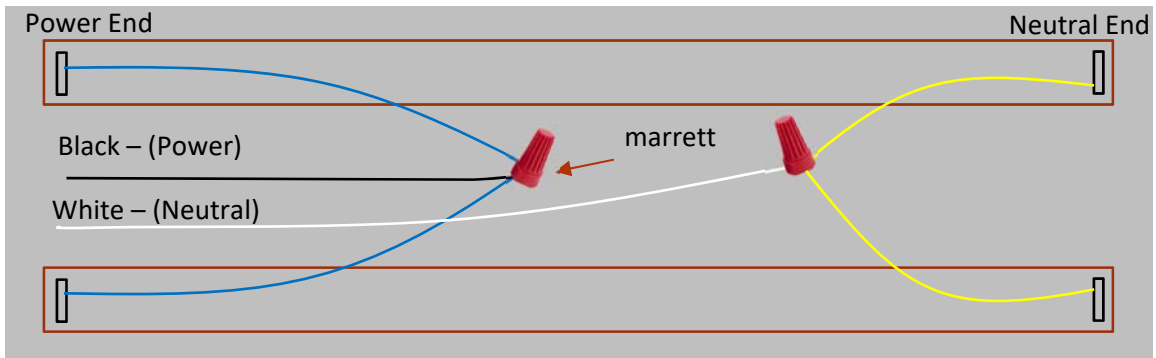

- Reinstall fixture cover
- Install LED tubes

## “Single End” LLT Style Tubes

Power and Neutral supplied to one end only

### Installing G13 Single-Ended Style LED tubes

There is a difference between the double-ended LED LLT and single-ended LED LLT when retrofitting for existing fluorescent fixtures. When installing a double-ended LED LLT, rewiring is required to bypass the ballast. In comparison, when installing a single-ended LED LLT, the retrofitting work involves both bypassing the ballast and rewiring the sockets (or tombstones).

### A word about Lamp Sockets and Wiring

Instant start electronic ballasts are the most common type of ballast in fluorescent fixtures, with rapid start magnetic ballasts usually only found in older fixtures. Rapid start ballasts are typically wired in series, while most instant start ballasts are wired in parallel. If a ballast is wired in series, this means that if one lamp fails or is intentionally removed, all lamps in the circuit will not be lit. Contrary, in a parallel circuit, should one lamp fail or intentionally be removed, all other lamps will remain lit and the ballast will continue to operate efficiently. Because of these wiring differences, different sockets are required for these different ballast types.

Fixtures containing rapid start ballasts are equipped with conventional sockets (Figure A) that are connected from the ballast by two wires per socket. Instant start ballasts on the other hand, require the use of a shunted socket (Figure B).

**Diagram 1 - Sockets**

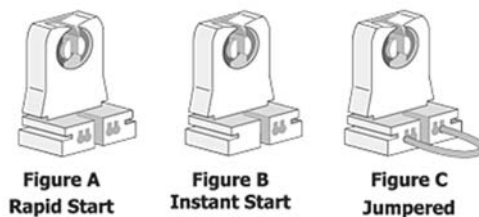

G13 Single Input end LED tubes have two (2) pins on each end of the tube like a standard LED or Fluorescent. However, with these fixtures they will require both Power and Neutral at **only one end** of the tube indicated with a sticker or engraving.



**Caution must be used as the two sockets of the tombstone of the existing fluorescent fixture may be purposely shorted or shunted. If it is shorted, it is not possible to retrofit a single-ended LLT without installing a new tombstone. You should first use an Ohm Meter to determine if the tombstone has been shorted.**

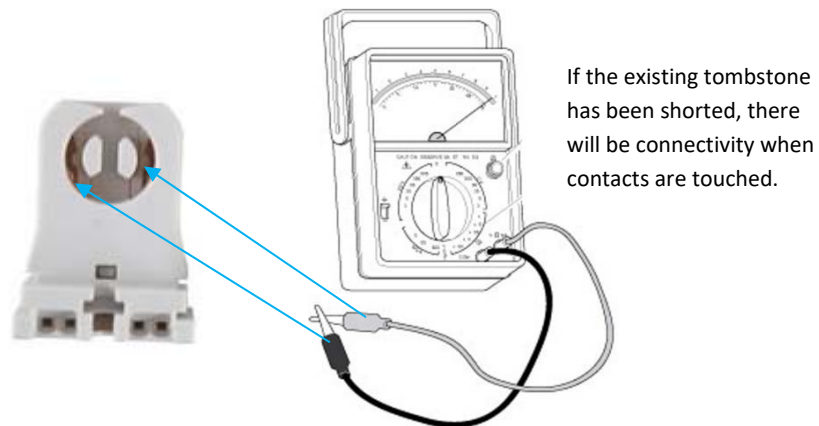

Typically, the single-ended LLT style tube is the easiest and fastest to install as the installer can make use of the two (2) existing wires running to the supply tombstone.

## 1. Install into a typical Double Lamp Series Electronic Ballast fixture

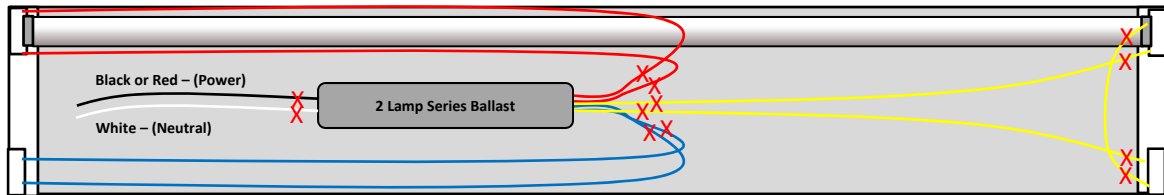

**NOTE:** When cutting wires, you may wish to salvage the existing working ballast so keep at least 2" - 3" of wire length. Try to salvage existing wire whenever possible in the fixture to use on the retrofit

- Remove existing ballast
- Configure an AC Input End in the fixture
- Test tombstone for continuity with Ohm Meter

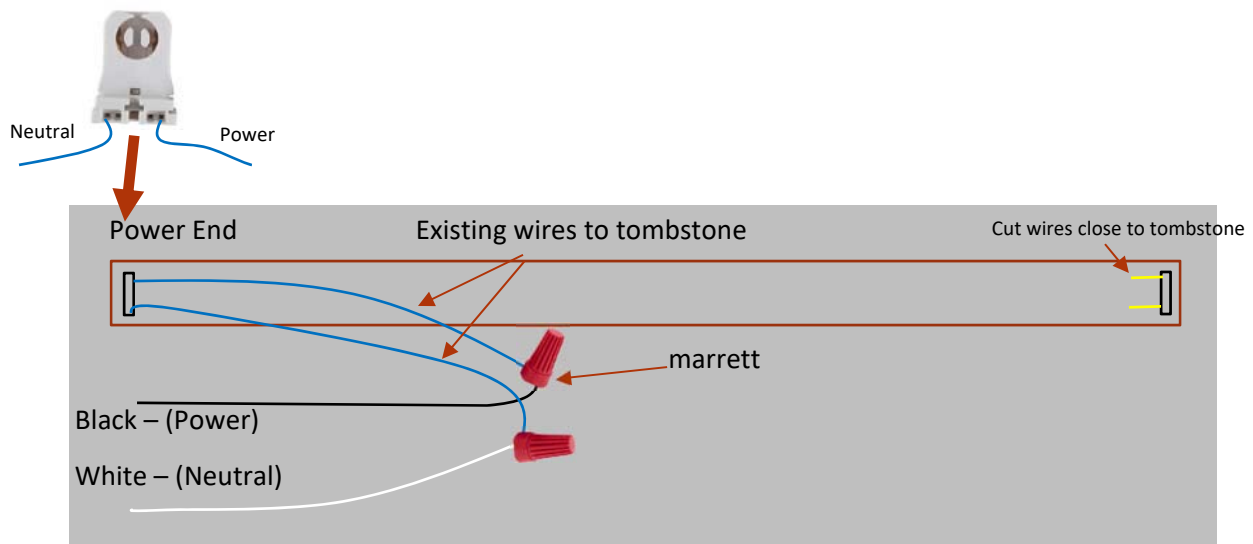



- Reinstall fixture cover
- Install LED tubes

## 2. Install into a typical Double Lamp Parallel Electronic Ballast fixture

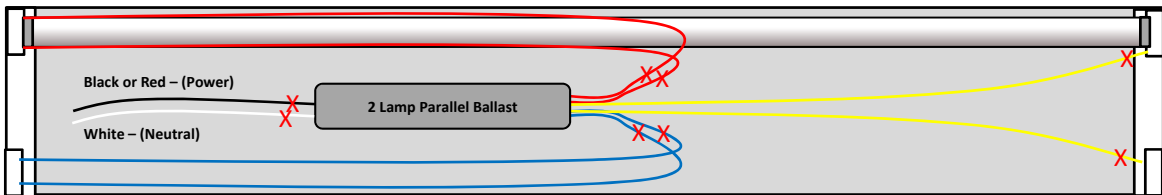

X=cut wires

- Remove existing ballast
- Configure an AC Input End in the fixture
- Test tombstone for continuity with Ohm Meter

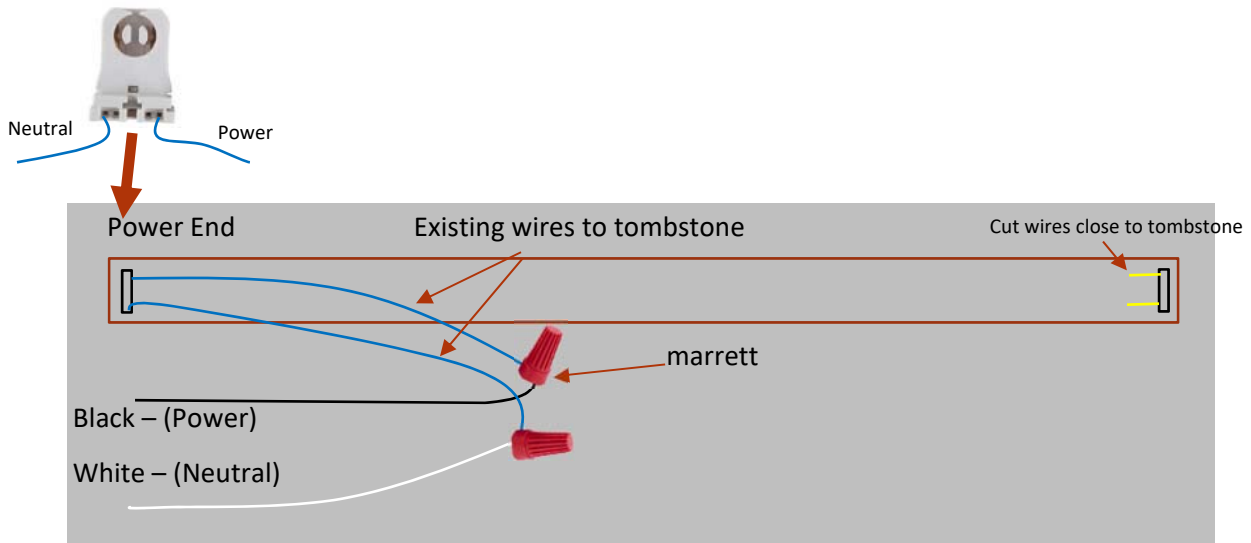

- Reinstall fixture cover
- Install LED tubes

## LED Hanger Install

A hanger clip is recommended to support the 8' single LED tube into the fixture. This will ensure that the tube does not get knocked out of the fixture. Drill a 3/32" hole to attach the T8 holders to the cover in the center.

Additional clips are available. (Please specify number)

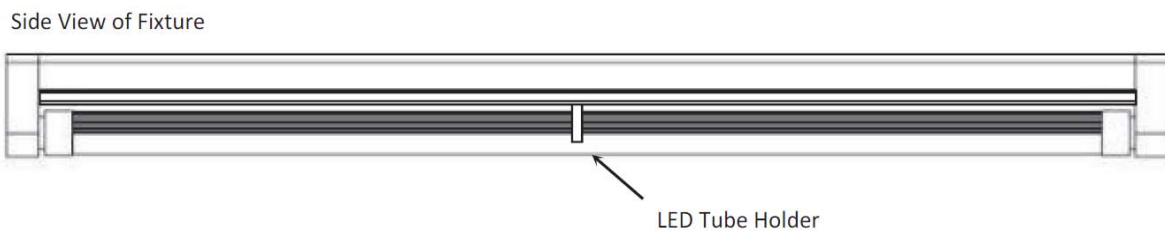
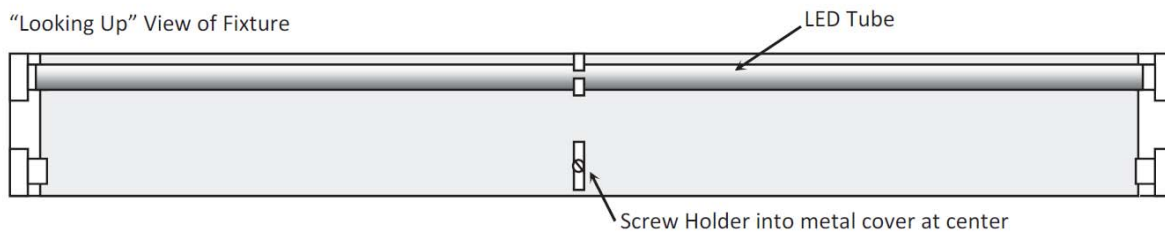

# APPENDIX

## Existing Wired Configuration for a Single Pin/Single Lamp Fixture w/ballast

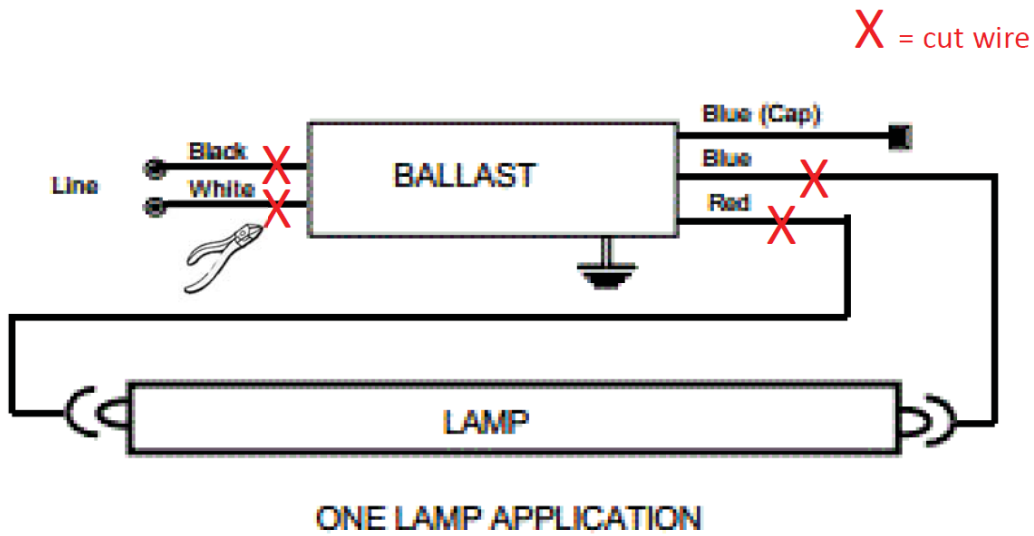

## New Configuration for LED Install

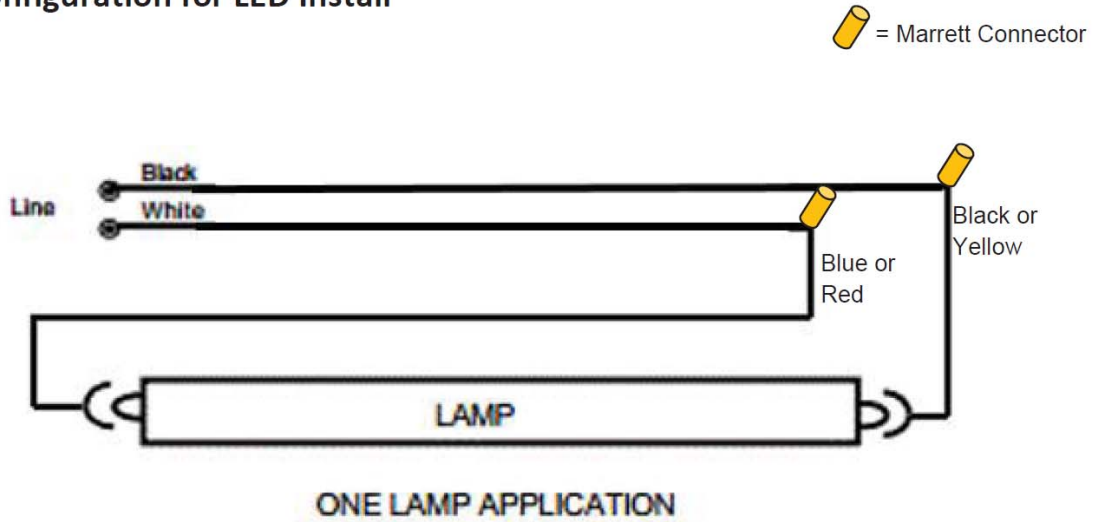

### Existing Wired Configuration for Single Pin/Two Lamp Fixture w/ballast

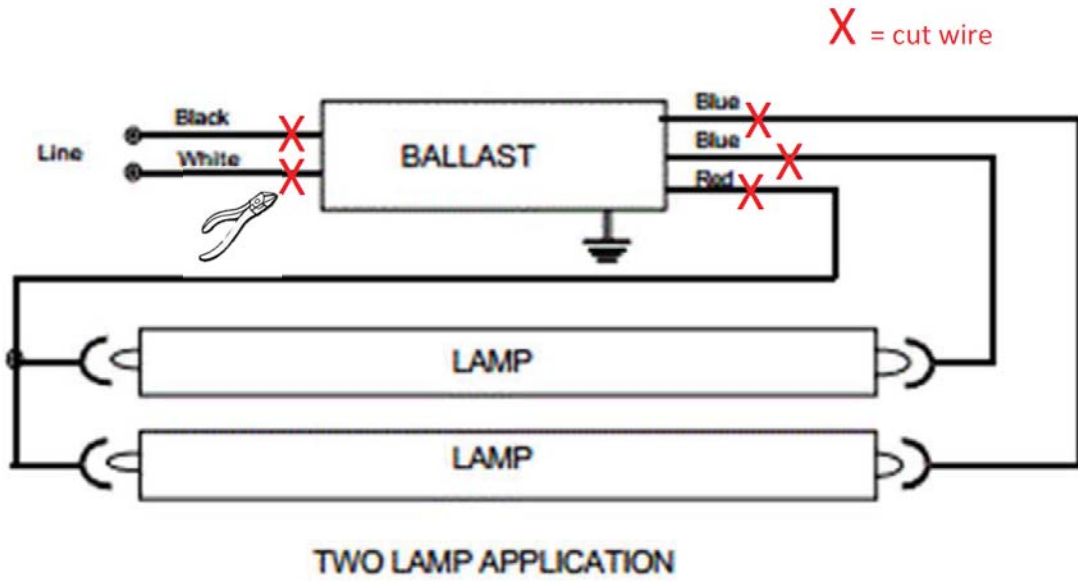

### New Configuration for LED Install

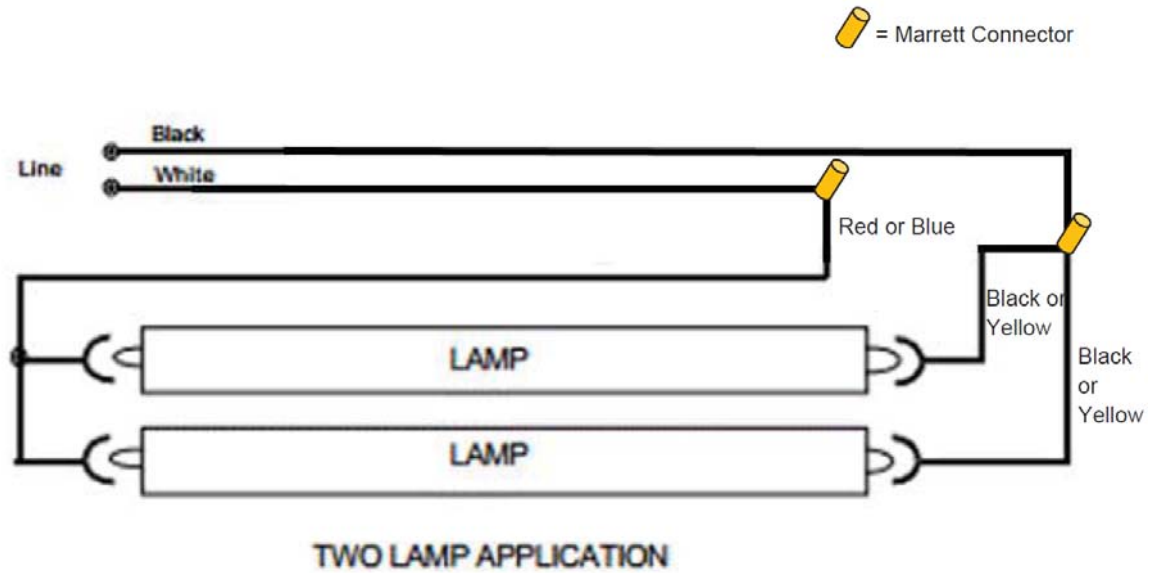

## Questions or Comments?

Please call 306-620-9566 or email

[Prowattsupply@outlook.com](mailto:Prowattsupply@outlook.com)

